



SAM ETCA43
Trip circuit supervision Relay

Features

- Low burden
- Trip circuit can be supervised with breaker open or closed
- Mis-tripping of breaker by accidental Short circuits avoided
- No false alarms given due to protection operation
- Manual and electrical reset

Application

The ETCA43 relay supervises the trip circuit to circuit breaker initiating audible alarm and visual indication if the trip circuit fails or the mechanism does not operate.

Audible giving supervision as follows

- Failure of trip supply
- Open circuit trip coil or trip circuit wiring
- Failure of circuit breaker tripping mechanism

The ETCA43 gives supervision with the circuit breaker in either state if required the alarm units it could operate via pilot wires

Description

Type ETCA43 consists of three units connected as shown in follow figure . Under healthy condition with the circuit breaker closed , both units are energized . If the trip circuit become open or the supply fails , unit RL2 drops off and opens contacts RL2-1 to de energize unit RL1 . when the drops off and opens the auxiliary switch shunts contact RL2-1 to hold in unit RL1 .

The units are delayed on drop off for a total of 400 ms , to prevent a false alarm due to voltage dips caused by faults in other circuits or during a normal tripping operation , when unit RL2 is momentarily short circuited by the self reset trip relay contact .

If the trip relay fails to reset due possibly to failure of the circuit breaker tripping , the Alarm is initiated .

When the circuit breaker is open , unit RL3 is also energized and via the normally closed auxiliary switch and unit RL1 is hold in by contact RL3-1 . unit RL3 detect trip circuit abnormalities with the circuit breaker open , in a similar manner to unit RL2 with the circuit breaker closed .

IEC STANDARD COMPLINACE

Immunity test

1. Radiated electromagnetic field immunity test
Port : Enclosure
IEC255-22-3
Test level : class2 - 3V/M
24-500 MHZ
The relay place under above criteria and no fail in operation appear .
2. voltage interruption and alternating ripple
IEC255-11
Test level : 125 ms-41 Vac
The power supply of relay interrupted as above and no fail in operation appear.
3. electrostatic discharge immunity test
Enclosure
IEC255-22-2
Test level : class 4
Contact discharge : 8 KV
Air discharge : 15 KV
Electrostatic charge discharge on enclosure under above criteria and no fail in operation appear.
4. fast transient (Burst) immunity test
Port : power supply –signal line
IEC255-22-4
Test level : class 4-2KV-comuon male
In this test 5Khz signal under above criteria applied on power supply and inputs and no fail in operation appear .

5. 1 MHz burst disturbance test
Port : power supply-signal line
IEC255-22-1
Test level : class 3
2.5 KV common mode – 1 KV differential mode

Insulation test

1. insulation resistance
port : input / output – Enclosure
IEC 255-5 IEC255-6
Test level 500 Vdc
The impedance between relay contacts, inputs and enclosure measured above 1 GΩ
2. Dielectric test
port : input / output – Enclosure
IEC 255-5 IEC255-6
Test level : series G
1.5 KVrms
The relay contacts and enclosure put under above criteria for 1 minute and no fail in operation appear.

Atmospheric environment

Temperature IEC 255-6

Storage and transit -25°C to 70°C
operating -25°C to +55°C

IEC 68-2-1 : 1 Cold
IEC 68-2-2 : 1 Dry heat

Humidity

IEC 68-2-3 : 1
56 days at 93% RH and + 40°C

Enclosure protection

IEC 529 IP50

Mechanical environment

Vibration

IEC 255-21-1

0.5g between 10Hz and 150 Hz

Mechanical durability

Loaded contact

10,000 operation minimum

Unloaded contact

100,000 operation minimum

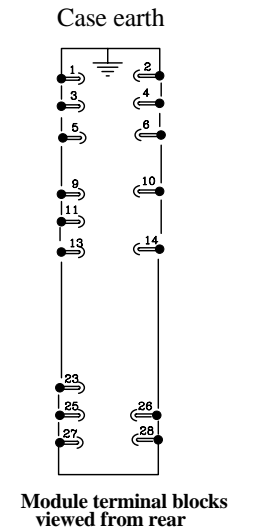
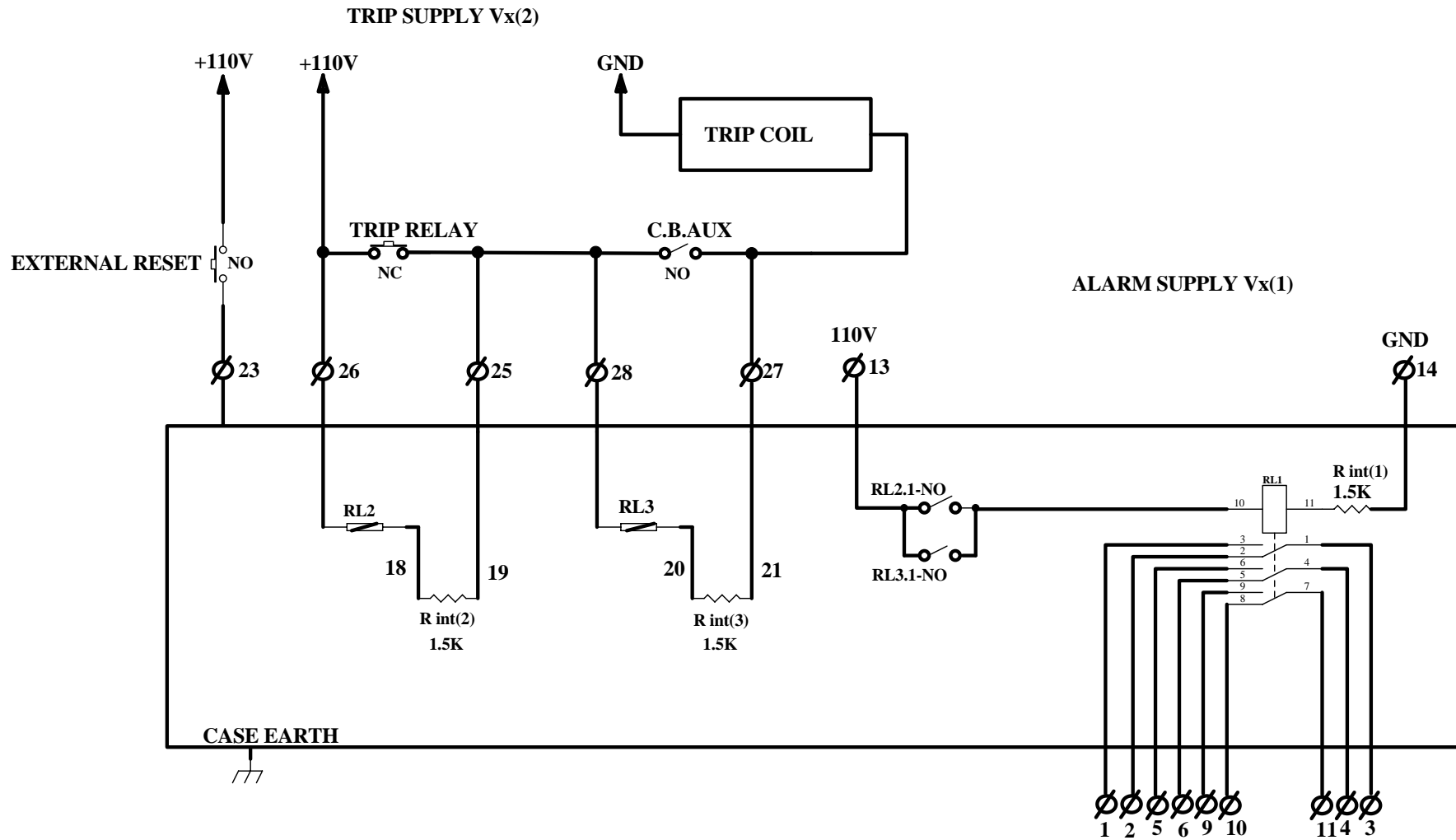

Title		
ETCA43		
Size	Number	Revision
B	Fig1	
Date:	27-Jun-2009	Sheet of
File:	E:\Product\TCSR\TCSR.ddb	Drawn By:

CASE DIMENSIONS

The relay is available in a 4U metal case for panel or flush mounting.

Weight :
front panel 177 mm
front panel 103 mm
front panel + case 252 mm

External size : Height case 152 mm
Width case 97 mm
Depth case 226 mm

